

STANDARD FEATURES

- Triple automatic levelling device for platform
- Narrow working road width - one traffic lane
- Two operating stations - platform and at turret.
- Personnel on bucket can control slow translation of the unit with permission of the driver in the cab
- Use for inspection of underbridge, bridge piers or road embankments

Specifications

| | |
|--------------------------------|-----------|
| Working height | 22.5 m |
| Platform height | 20.5 m |
| Platform swivel | 280° |
| Side reach | 9 m |
| Downward | 27.5 m |
| Downward to underbridge | 7.7 m |
| Underbridge reach | 22 m |
| Under bridge boom articulation | 4.5 m |
| Platform capacity | 300 kg |
| Overall length stowed | 12.55 m |
| Stowed height | 4 m |
| Overall width | 2.5 m |
| Total vehicle weight | 33,000 kg |

WORK RANGE DIAGRAM UNDER BRIDGE

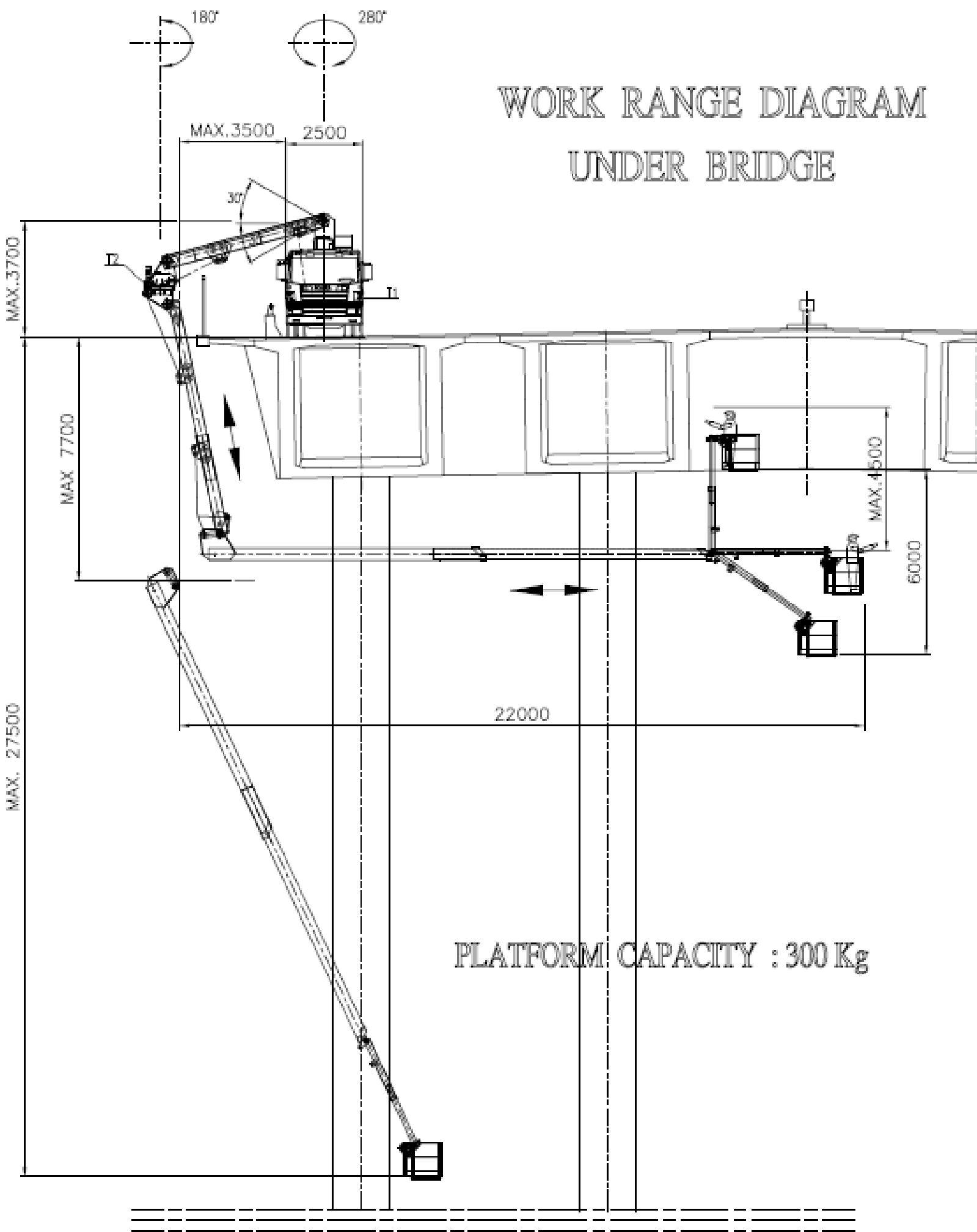

WORK RANGE DIAGRAM OVERHEAD

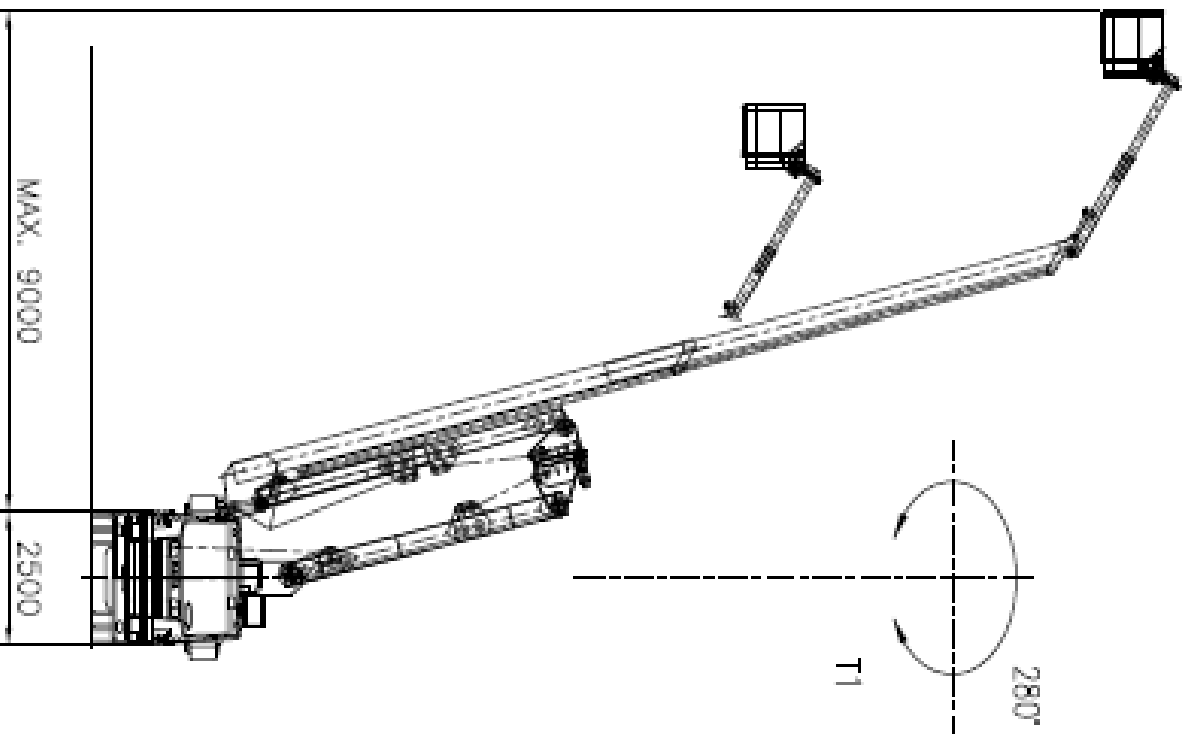
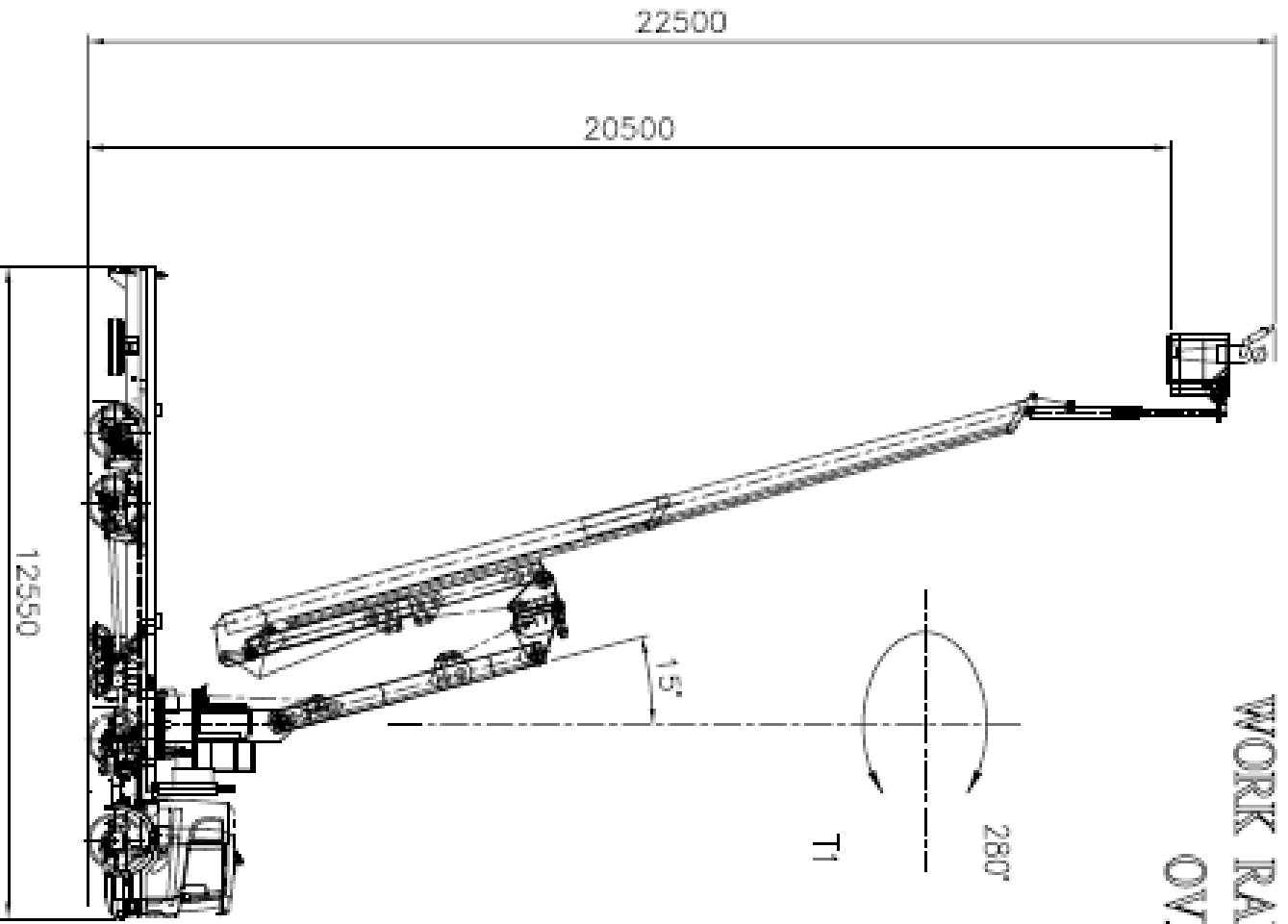

OVERALL DIMENSIONS IN ROAD TRANSPORT POSITION

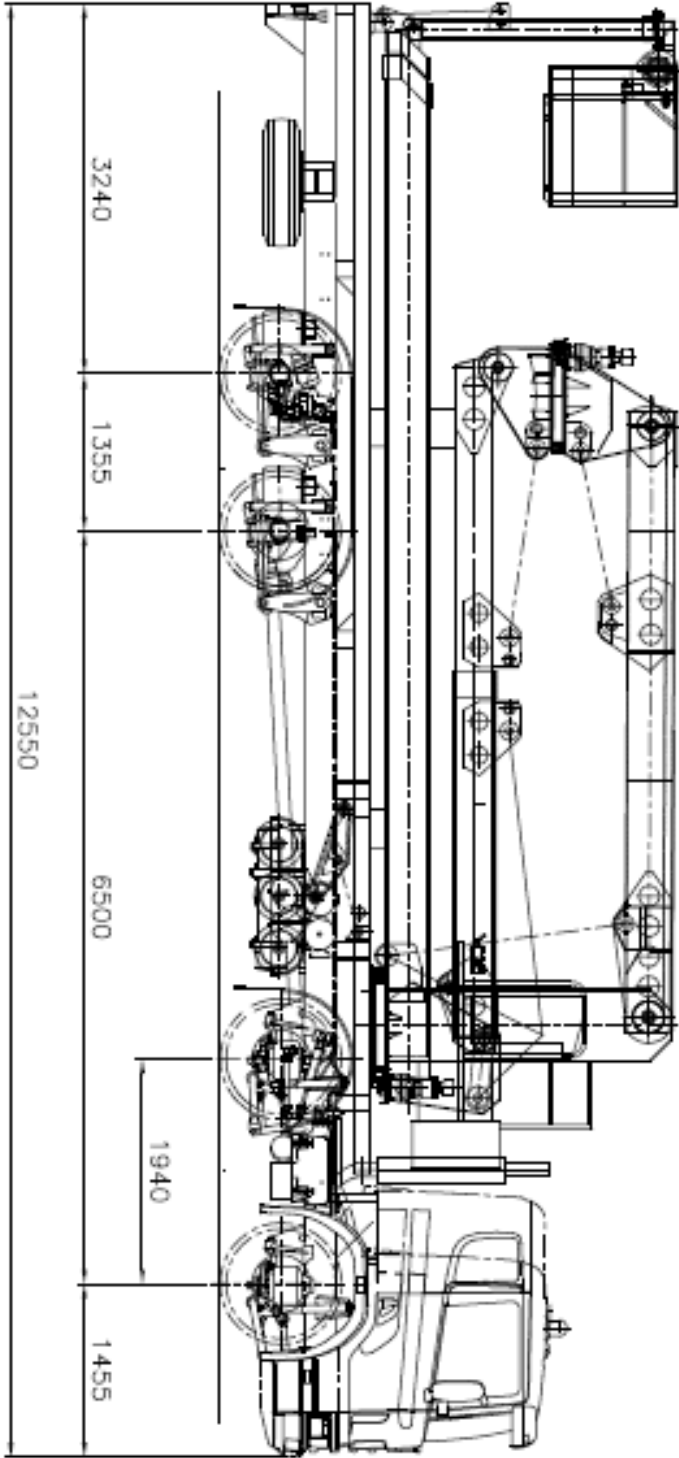

20.000 KG

13.000 KG

